

WASHER SPECIFICATIONS

The Pamargan bonded seal is a rectangular section, metal washer, with a trapezoidal shaped ring of vulcanised rubber bonded to the inside. Both the washer and the material can be selected to suit a given application. The seal is for use in high pressure environments where copper washers are unsuitable.

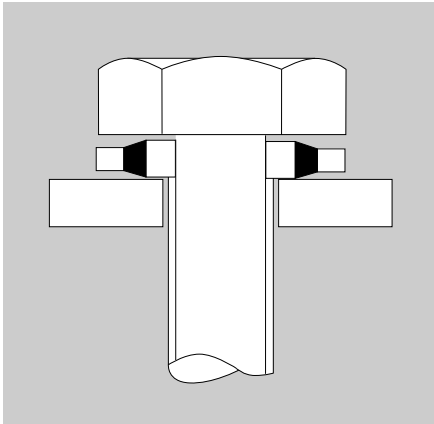

An improvement to the original concept is the self-centring bonded seal - designed by Pamargan - that offers additional benefits. It is available in all popular BSP sizes and many other metric sizes.

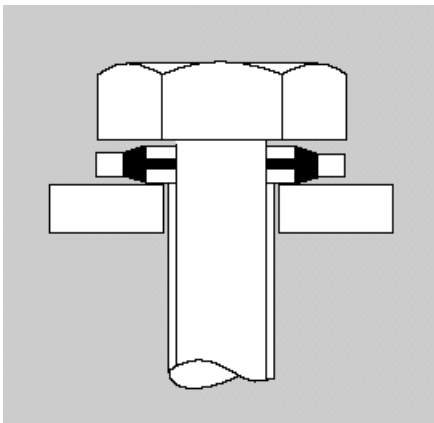

METAL	TENSILE STRENGTH MN/m ² (MINIMUM)	SPECIFICATION
Mild Steel Pressings	540	BS 1449 Part 1 CS4 BRH5
Mild Steel Turned	540	BS 970 Part 1 EN8
Stainless Steel Pressings	540	BS 1449 Part 2 T316
Stainless Steel Turned	540	BS 970 Part 1 T303
Stainless Steel Turned	540	BS 970 Part 1 T316
Stainless Steel Turned	540	BS 970 Part 1 T304
Brass Turned	380	BS 2874 CA104
Brass Pressings	380	BS 2870 CZ108
Aluminium Bronze Turned	700	BS 2874 CA104
Aluminium Alloy Turned	370	L102 & L168
High Tensile Steel	880	S154
Aluminium Alloy Turned	370	HE 30 (6086 - T6)

SURFACE FINISH	SPECIFICATION
Zinc Plating	Def. STAN. 03-20
Gold Passivate	Def. STAN. 03-33
Cadmium Plating	Def. STAN. 03-19
Chromic Anodise	Def. STAN. 03-24/2
Sulphuric Anodise	Def. STAN. 03-25/2
Clear Passivate	Fe/Zn-5CIA
Zinc/Cobalt and Colour Passivate	ZnCb-921/ST140
Mechanical Zinc Plate	STD. 5735,114 Fe/Zn 8 C1
Zinc/Iron and Black Chromate	Fe/Zn - Fe 5 C4
Sherardize 2000	SHS 1091

TORQUE LOADING

Satisfactory performance of the seal depends on correct torque loading during assembly. The following table indicates recommended figures.

For double sealing, additional torque is generally required.

THREAD SIZE			TORQUE REQUIRED		DOUBLE SEALING FACTOR
METRIC	BOLT	BSP	Nm	lbf.in	
Up to 8	5/16	-	5.3	47+/-3	1.6
10	3/8	1/8	7.1	63+/-3	
11	7/16	-	11.8	105+/-5	1.3
12	1/2	1/4	15.8	140+/-5	
14	9/16	-	22.6	200+/-10	
16	5/8	3/8	30.5	270+/-12	
18	3/4	-	40.7	360+/-15	1.2
20	13/16	1/2	56.5	500+/-25	
22	7/8	5/8	67.8	600+/-30	1.1
24	1.0	3/4	73.4	650+/-30	1.0
27+	1.1/16	-	79.0	700+/-35	

RUBBER SPECIFICATIONS

Nitrile is based on an Acrylonitrile Butadiene Copolymer material that is resistant to all mineral oils, water and watery liquids, hot air and numerous chemicals. It is a general purpose rubber and is used in a variety of applications.

Fluorocarbon material is based on a Fluorocarbon elastomer with an operating temperature of +250°C to -25°C

and is resistant to mineral oils, petrols, a wide range of solvents and many chemicals. In this respect fluorocarbon is superior to other oil resistant materials such as nitrile (NBR) rubber.

Hydrogenated Nitrile (HNBR) is a compound with an operating temperature range of +150°C continuous (10,000 hrs) to -30°C continuous.

HNBR has higher tensile strength and wear resistance than NBR, five times higher sour gasoline and ozone resistance. The material is highly efficient in oil wells, with resistance to heat, hydrogen sulphide, corrosion inhibitor, oil and steam. HNBR has wide applications in the auto and oil industries.

NITRILE NBR	
Temp. Range: -30°C to +110°C	
Physical Properties	
Hardness IRHD	80-90
Tensile strength Mpa	10.34 Min
Elongation at Break %	100 Min
Specific Gravity	1.34 +/-0.02
Air Aged 70 hours at 100°C	
Hardness change (points)	+/- 15 Max
Tensile strength change %	+/-30 max
Elongation change %	-50 Max
Compression Set	
22 hours at 100°C%	25 max
Aged in ASTM no.1 oil 70 hours at 100°C	
Hardness change (points)	-5 to +15
Tensile strength change %	-25 Max
Elongation change %	-45 Max
Volume change %	-10 to +5
Aged in ASTM no.3 oil 70 hours at 100°C	
Hardness change (points)	-10 to +5
Tensile strength change %	-45 Max
Elongation change %	-45 Max
Volume change %	-0 to +25 Max
Aged in ASTM fuel A 70 hours at Room Temp.	
Hardness change (points)	+/-10
Tensile strength change %	-25 Max
Elongation change %	-25 Max
Volume change %	-5 to +10
Aged in ASTM fuel B 70 hours at Room Temp.	
Hardness change (points)	0 to -30
Tensile Strength change %	-60 Max
Elongation change %	-60 Max
Volume change %	0 to +40 Max
Aged in Water 70 hours at 100°C	
Hardness change (points)	+2.4
Volume change %	+1

FLUOROCARBON	
Temp. Range: -25°C to +250°C	
Physical Properties	
Hardness IRHD	75-85
Tensile strength Mpa	12 Min
Elongation at Break %	200
Specific Gravity	1.83 +/-0.02
Air Aged 168 hours at 200°C	
Hardness change (points)	+5 Max
Tensile strength change %	-10 Max
Elongation change %	-25 max
Compression Set	
70 hours at 150°C%	+20 max
Aged in ASTM no.1 oil 7 days at 150°C	
Volume change %	+2
Aged in ASTM no.3 oil 7 days at 150°C	
Volume change %	+2.5
Aged in ASTM Fuel A 3 days at 23°C	
Volume change %	+5 max
Aged in ASTM Fuel B 7 days at 23°C	
Volume change %	+2.5
Aged in ASTM Fuel C 3 days at 23°C	
Volume change %	+4.5
Aged in ASTM Fuel D 3 days at 23°C	
Volume change %	+4.8

HYDROGENATED NITRILE HNBR	
Temp. Range: -30°C to +150°C	
Physical Properties	
Hardness IRHD	75-85
Tensile strength Mpa	22.4
Elongation at Break %	210
Specific Gravity	1.19+/-0.02
Air Aged 168 hours at 150°C	
Hardness change (points)	+5
Tensile strength change %	-14.8
Elongation change %	-36.5
Compression Set	
70 hours at 150°C%	+25 max
Aged in ASTM no.1 oil 168 hours at 150°C	
Hardness change (points)	-1.0
Tensile strength change %	-14.5
Elongation change %	-22.5
Volume change %	+2.9
Aged in ASTM no.3 oil 168 hours at 150°C	
Hardness change (points)	-8.0
Tensile strength change %	-53.4
Elongation change %	-52.61
Volume change %	+24.2
Aged in Ethylene Glycol 70 hours at 115°C.	
Tensile strength change %	-4.6
Elongation change %	-3.8
Volume change %	+0.96

RUBBER COMPATIBILITY

The characteristics of the compounds used and their compatibility rating against various fluids are summarised in the following table.

	NITRILE (NBR)	HYDROGENATED NITRILE (HNBR)	FLUOROCARBON (VITON f)	SILICONE	FLUOROSILICON	ETHYLENE PROPYLENE	CHLOROPRENE (NEOPRENE f)
General Characteristics							
Hardness range IRHD	40-90	40-85	60-90	40-80	40-80	80-90	40-80
Continuous high temperature limit	110°C	150°C	225°C	250°C	175°C	120°C	140°C
Low temperature capability	-30°C	-30°C	-25°C	-75°C	-65°C	-30°C	-55°C
Dynamic service/Abrasion resistance	Excellent	Excellent	Very Good	Poor	Poor	Fair	Very Good
Compression set resistance	Very Good	Excellent	Very Good	Excellent	Very Good	Very Good	Good
FLUID COMPATIBILITY							
Acid – Inorganic	Fair	Good	Excellent	Good	Good	Good	Fair/Good
Acid – Organic	Good	Good	Good	Excellent	Good	Good	Good
Ageing – Oxygen	Fair	Good	Very Good	Excellent	Excellent	Excellent	Very Good
Ageing – Ozone	Fair/Poor	Good	Very Good	Excellent	Excellent	Excellent	Very Good
Ageing – Weather	Poor	Good	Very Good	Excellent	Excellent	Excellent	Very Good
Air	Fair	Excellent	Very Good	Excellent	Very Good	Excellent	Good
Alcohols	Very Good	Excellent	Fair	Very Good	Very Good	Very Good	Very Good
Aldehydes	Fair/Poor	Fair	Poor	Good	Poor	Very Good	Fair/Poor
Alkalis	Fair/Poor	Fair	Good	Very Good	Good	Very Good	Good
Amines	Poor	Poor	Poor	Good	Poor	Good	Very Good
Animal oils	Excellent	Excellent	Very Good	Good	Excellent	Very Good	Good
Esters – Alkyl Phosphate (Skydrol)	Poor	Poor	Poor	Good	Fair/Poor	Fair/Good	Poor
Esters – Aryl Phosphate	Fair/Poor	Fair	Excellent	Good	Very Good	Fair	Fair/Poor
Esters – Silicate	Good	Good	Excellent	Poor	Very Good	Fair	Fair
Ethers	Poor	Poor	Poor	Poor	Fair	Poor	Poor
Gas permeability	Good	Good/Excellent	Very Good	Poor	Poor	Good	Good
Hydrocarbon fuels – Aliphatic	Excellent	Excellent	Excellent	Fair	Excellent	Poor	Fair
Hydrocarbon fuels – Aromatic	Good	Excellent	Excellent	Poor	Very Good	Poor	Fair/Poor
Hydrocarbons – Halogenated	Fair/Poor	Poor	Excellent	Poor	Very Good	Good	Poor
Ketones	Poor	Poor	Poor	Poor	Fair/Poor	Very Good	Poor
Lubricating oils – High aniline	Excellent	Excellent	Excellent	Very Good	Very Good	Poor	Good
Lubricating oils – Low aniline	Very Good	Excellent	Excellent	Fair	Poor	Poor	Fair/Poor
Silicone oils	Excellent	Excellent	Excellent	Good	Excellent	Very Good	Excellent
Vegetable oils	Excellent	Excellent	Excellent	Excellent	Excellent	Very Good	Good
Water/steam	Excellent	Excellent	Fair	Fair	Fair	Excellent	Fair

CETOPS (RECOMMENDED IN ISO 1179-1973)

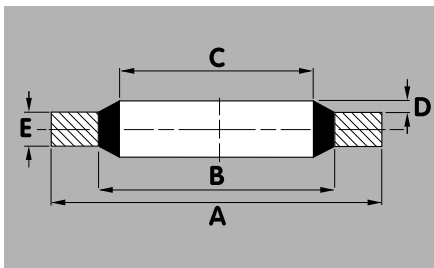

ASHTON REFERENCE	THREAD SIZE BSPF	A +0.00 -0.20	B +0.20 -0.00	C +0.20 -0.00	D +0.25 -0.00	E +0.15 -0.15	MIN. BURST PRESSURE (BAR)
519	1/16	12.70	9.90	8.30	0.25	1.25	1100
510	1/8	14.70	12.00	10.40			930
511	1/4	18.70	15.75	13.85			790
512	3/8	22.70	19.25	17.35			775
513	1/2	26.70	23.55	21.65			580
514	3/4	32.50	29.20	27.30		500	
515	1.0	39.50	36.10	34.20		410	
516	1.1/4	49.50	44.70	42.80		2.00	500
517	1.1/2	55.50	50.60	48.70			430
518	2.0	68.50	62.40	60.50			445

ASHTON REFERENCE	THREAD SIZE BSPF	A +0.00 -0.20	B +0.20 -0.00	C +0.20 -0.00	D +0.25 -0.00	E +0.15 -0.15	MIN. BURST PRESSURE (BAR)
501	1/8	16.20	12.00	10.40	0.25	1.25	930
502	1/4	20.20	15.75	13.85			790
503	3/8	24.20	19.25	17.35			775
504	1/2	29.20	23.55	21.65			580
505	3/4	35.00	29.20	27.30			500
506	1.0	43.00	36.10	34.20		410	
507	1.1/4	53.00	44.70	42.80		2.00	500
508	1.1/2	59.00	50.60	48.70			430
509	2.0	73.00	62.40	60.50			445

Note: There is a permitted moulding flashline on the inner diameter C. All dimensions in mm in accordance with AGS 1186

IMPERIAL BONDED SEALS

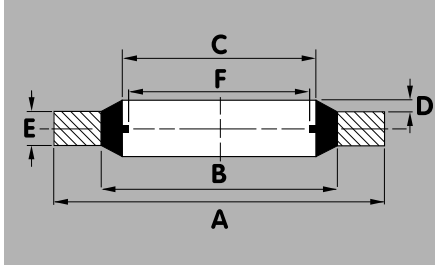
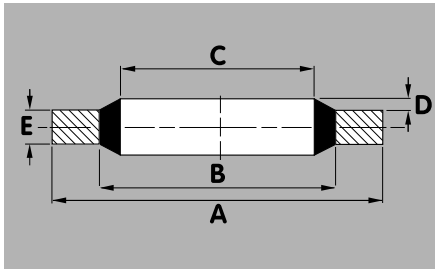

KEY FEATURES OF SELF-CENTRALISING:

1. Elimination of seal offset
2. Elimination of leaks
3. Ease of installation
4. Reduced assembly time
5. Captive assembly

When ordering self-centring bonded seals change first digit of Ashton reference to an 8 e.g. 823

PLEASE NOTE: check availability of self-centring bonded seals before ordering

ASHTON REFERENCE	ALT. REF.	SIZE		A	B	C	D	E	F	MIN. BURST PRESSURE (BAR)
		BSP	BOLT							
001	PP45-1	-	6BA	6.35	4.09	3.05	0.20/ 0.45	1.22	-	2150
002	PP45-2	-	4BA	7.26	5.26	4.12			-	1570
003	PP45-3	-	2BA	8.38	6.35	5.21			-	1375
004	PP45-4	-	1/4	13.21	8.00	6.86			4.70	2450
005	PP45-5	-	1/4	13.34	9.53	6.99			4.70	1700
006	PP45-6	-	5/16	13.34	9.53	8.31			6.10	1700
007	PP45-7	-	5/16	14.22	10.04	8.64			6.10	1750
020	PP45-A	1/8	3/8	15.88	11.84	10.37	0.25/ 0.51	2.03	8.56	1500
008	PP45-8	-	0.4	18.36	12.45	11.26			8.56	1950
009	PP45-9	-	7/16	19.05	13.08	11.69			8.80	1900
021	PP45-B	1/4	1/2	20.57	15.21	13.74			11.45	1550
010	PP45-10	-	9/16	22.23	16.39	14.86			11.58	1575
022	PP45-BB	-	0.6	22.23	17.30	15.83			12.10	1310
011	PP45-11	-	5/8	25.40	18.75	16.51			12.90	1550
023	PP45-C	3/8	-	23.80	18.75	17.28			14.96	1260
012	PP45-12	-	11/16	25.40	19.69	18.16			14.50	1320
024	PP45-CC	-	3/4	26.92	21.21	19.69			15.80	1260
025	PP45-D	1/2	13/16	28.58	23.01	21.54			18.64	1150
026	PP45-E	5/8	7/8	31.75	24.97	23.49			20.60	1250
013	PP45-13	-	15/16	33.27	26.04	24.26			20.20	1275
027	PP45-F	3/4	1.0	34.93	28.53	27.05			24.13	1060
028	PP45-FF	-	1.1/16	38.61	30.61	27.82	22.90	1250		
014	PP45-14	-	1.1/8	36.58	30.86	29.33	23.90	900		
031	PP45-HH	1.0	1.5/16	42.80	36.88	33.89	30.30	810		
029	PP45-G	7/8	1.3/16	38.10	32.29	30.81	27.89	900		
015	PP45-15	-	1.1/4	41.40	35.69	32.64	27.10	800		
030	PP45-H	1.0	1.5/16	42.80	36.88	33.89	30.30	810		
016	PP45-16	-	1.3/8	44.45	38.99	35.94	29.50	700		
017	PP45-17	-	1.1/2	47.75	42.04	38.96	32.70	700		
032	PP45-J	1.1/4	1.5/8	52.38	45.93	42.93	38.96	690		
018	PP45-18	-	1.3/4	57.15	48.39	45.34	37.90	875		
033	PP45-K	1.1/2	1.7/8	58.60	51.39	48.44	44.86	690		
019	PP45-19	-	2.0	63.50	54.74	51.69	43.60	780		
034	PP45-L	1.3/4	2.1/8	69.85	58.30	54.89	50.80	950		
036	PP45-M	2.0	-	73.03	63.63	60.58	56.67	700		
037	PP45-MM	-	2.1/2	77.72	67.44	64.39	55.40	750		
038	PP45-N	2.1/4	-	79.50	69.98	66.68	65.80	670		
039	PP45-P	2.1/2	-	90.17	79.38	76.08	72.20	680		
079	-	3.0	-	101.47	92.84	89.09	85.00	550		

Note: There is a permitted moulding flashline on the inner diameter C in accordance with AGS 1186

All dimensions in mm

9000 SERIES -

HIGH QUALITY LOWER COST

By utilising advanced techniques for the manufacture of washers and standardising on washer thickness where possible, a NEW LOWER COST OPTION to all the popular B.S.P sizes is now available, using the same quality of material as our regular range.

STANDARD

ASHTON REFERENCE	SIZE		A	B	C	D	E	MIN. BURST PRESSURE (BAR)
	BSP	BOLT						
9020	1/8	3/8	15.88	11.84	10.37	0.25	2.00	1500
9021	1/4	1/2	20.57	15.21	13.74			1550
9023	3/8	-	23.80	18.75	17.28			1260
9025	1/2	13/16	28.58	23.01	21.54			1150
9027	3/4	1.00	34.93	28.53	27.05			1060
9030	1.00	1.5/16	42.80	36.88	33.89			810
9032	1.1/4	1.5/8	52.38	45.93	42.93			690

All dimensions in mm

SELF-CENTRALISING

ASHTON REFERENCE	SIZE		A	B	C	D	E	F	MIN. BURST PRESSURE (BAR)
	BSP	BOLT							
9820	1/8	3/8	15.88	11.84	10.37	0.25	2.00	8.56	1500
9821	1/4	1/2	20.57	15.21	13.74			11.45	1550
9823	3/8	-	23.80	18.75	17.28			14.96	1260
9825	1/2	13/16	28.58	23.01	21.54			18.64	1150
9827	3/4	1.00	34.93	28.53	27.05			24.13	1060
9830	1.00	1.5/16	42.80	36.88	33.89			30.30	810
9832	1.1/4	1.5/8	52.38	45.93	42.93			38.96	690

All dimensions in mm

GERMAN METRIC BONDED SEALS

ASHTON REFERENCE	ALTERNATIVE REFERENCE	A	B	C	D	E	F	MIN. BURST PRESSURE (BAR)
		+0.13 -0.00	+0.10 -0.10	+0.10 -0.10	+0.25 -0.00	+0.10 -0.10	+0.20 -0.20	
201	PPM3.5	7.20	5.20	4.10	0.30	1.00	-	1600
202	PPM4	7.00	5.40	4.50			3.40	1250
203	PPM5	9.00	6.80	5.70			4.50	1400
204	PPM5	10.00	7.40	5.70			4.50	1500
205	PPM5.5	9.20	7.20	6.20			4.70	1220
206	PPM6	10.00	8.00	6.70			4.70	1130
207	PPM6	11.00	8.20	6.70			4.70	1510
212	PPM8	13.00	10.00	8.70			6.40	1330
213	PPM8	14.00	10.40	8.70			6.40	1550
215	PPM8.5	13.30	10.50	9.30			6.90	1200
216	PPM10	15.88	12.00	10.35		2.00	8.56	1450
217	PPM10	16.00	12.40	10.70		8.05	1350	
218	PPM10	18.00	12.40	10.70		8.05	1880	
219	PPM11	16.30	12.70	11.40		9.80	1250	
221	PPM11	19.10	13.50	11.80		9.80	1770	
222	PPM12	18.00	14.30	12.70		9.73	1250	
223	PPM12	20.00	14.40	12.70		9.73	1680	
225	PPM13	22.00	15.40	13.70		10.80	1810	
226	PPM13.5	18.70	15.70	14.00		11.30	900	
227	PPM14	22.00	16.40	14.70		11.38	1510	
229	PPM16	24.00	18.40	16.70	13.41	1400		
230	PPM17	24.00	19.20	17.40	13.08	1150		
231	PPM17.5	24.70	20.10	18.00	13.60	1070		
232	PPM18	26.00	20.40	18.70	14.76	1275		
233	PPM20	28.00	22.50	20.70	16.76	1150		
234	PPM21	28.70	23.30	21.50	2.50	17.80	1080	
236	PPM22	30.00	24.40	22.70	0.40	1.50	18.74	1100
238	PPM24	32.00	26.40	24.70			20.11	1050
239	PPM26	35.00	28.40	26.70			22.30	1050
240	PPM27	36.00	29.00	27.20			23.30	1130
242	PPM30	39.00	33.00	31.00			25.70	860
243	PPM33	42.00	35.80	33.70		28.70	900	
244	PPM33	46.00	36.40	34.30		28.70	880	
245	PPM36	46.00	38.80	36.70		31.10	880	
246	PPM39	51.00	41.90	40.00		2.50	34.10	1020
247	PPM42	53.00	44.40	42.70		0.40	2.00	36.50
248	PPM48	59.00	50.80	48.70	41.90			800
254	PPM88	101.35	92.10	89.09	3.25			-

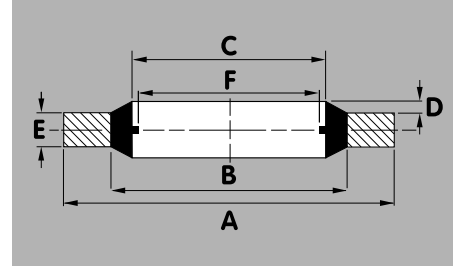
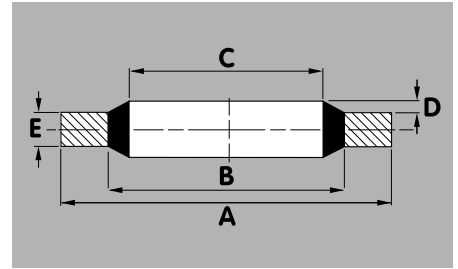

KEY FEATURES OF SELF-CENTRALISING:

1. Elimination of seal offset
2. Elimination of leaks
3. Ease of installation
4. Reduced assembly time
5. Captive assembly

When ordering self-centralising bonded seals change first digit of Ashton reference to a 6 e.g. 612

PLEASE NOTE: check availability of self-centralising bonded seals before ordering

Note: There is a permitted moulding flashline on the inner diameter C in accordance with AGS 1186

All dimensions in mm

NEW PM1000 METRIC RANGE

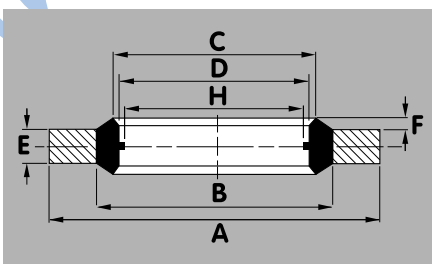
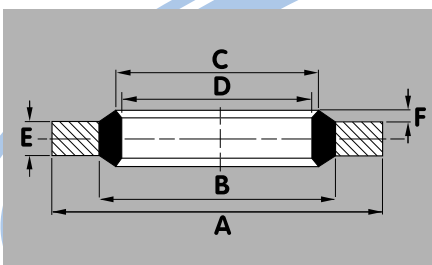

ASHTON REFERENCE	SIZE	A	B	C	D	E	F	H	MIN. BURST PRESSURE (BAR)
		+0.20 -0.20	+0.20 -0.20	+0.20 -0.20	+0.20 -0.20	+0.20 -0.20	+0.10 -0.10	+0.20 -0.20	
3099	M6	10.0	8.0	7.4	6.0	1.0	0.40	4.70	1130
3138	M8	14.0	11.0	10.0	8.0			6.40	1200
3076	M10	17.0	13.0	12.0	10.0	1.5	0.50	8.56	1250
3077	M12	19.0	16.0	15.0	12.0			9.73	1250
3063	M14	22.0	18.0	17.0	14.0			11.38	1100
3078	M16	24.0	20.0	19.0	16.0			13.41	1050
3064	M18	27.0	22.0	21.0	18.0			14.76	1100
3079	M20	30.0	25.0	24.0	20.0			16.76	1050
3098	M22	32.0	27.0	26.0	22.0			18.74	1000
3080	M24	36.0	29.0	28.0	24.0			20.11	1130
3065	M26	35.0	30.5	30.0	26.0			22.30	850

Note: There is a permitted moulding flashline on the inner diameter C in accordance with AGS 1186

When ordering self-centralising bonded seals change first digit of Ashton reference to a 4 e.g. 4076. PLEASE NOTE: check availability before ordering

☑ FRENCH METRIC BONDED SEALS

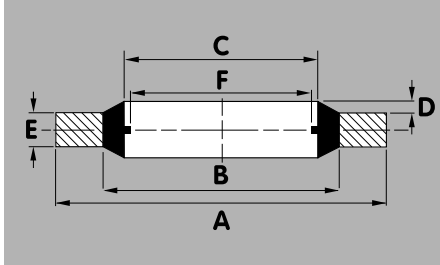
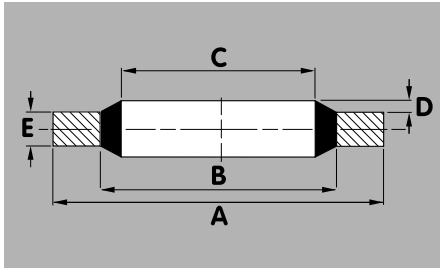

KEY FEATURES OF SELF-CENTRALISING:

1. Elimination of seal offset
2. Elimination of leaks
3. Ease of installation
4. Reduced assembly time
5. Captive assembly

When ordering self-centralsing bonded seals change first digit of Ashton reference to a 7 e.g. 712

PLEASE NOTE: check availability of self-centralsing bonded seals before ordering

ASHTON REFERENCE	ALTERNATIVE REFERENCE	A +0.13 -0.00	B +0.10 -0.10	C +0.10 -0.10	D +0.25 -0.00	E +0.10 -0.10	F +0.20 -0.20	MIN. BURST PRESSURE (BAR)	
301	PPFM3	7.50	5.00	3.60	0.30	1.00	-	1950	
302	PPFM4	9.00	6.00	4.60			3.40	2000	
303	PPFM5	10.00	7.00	5.60			4.50	1780	
304	PPFM6	11.00	8.00	6.60			4.70	1680	
306	PPFM6	11.40	8.40	7.00			4.70	1540	
307	PPFM8	13.00	10.00	8.60			6.40	1330	
310	PPFM10	17.00	12.10	10.70			1.50	8.56	1730
312	PPFM11	18.10	13.20	11.80				9.80	1600
313	PPFM12	19.00	14.10	12.70				9.73	1530
315	PPFM13	20.10	15.20	13.80				10.80	1440
316	PPFM14	21.00	16.10	14.70	11.38	1370			
317	PPFM16	23.00	18.10	16.70	11.41	1240			
318	PPFM17	23.70	18.80	17.40	13.08	1200			
320	PPFM18	27.00	20.40	18.70	0.40	14.76		1450	
321	PPFM20	29.00	22.40	20.70		16.76		1340	
323	PPFM21	30.00	23.40	21.70		17.80		1290	
324	PPFM22	31.00	24.40	22.70		18.74	1240		
325	PPFM23	32.00	25.40	23.70		19.30	960		
326	PPFM24	33.00	26.40	24.70		20.11	1160		
327	PPFM26	35.30	28.70	27.00		22.30	870		
328	PPFM27	36.00	29.40	27.70		23.30	1060		
329	PPFM28	36.00	30.30	28.60		24.80	730		
331	PPFM30	39.00	32.40	30.70		25.70	970		
332	PPFM33	42.00	35.40	33.70	28.70	900			
333	PPFM36	48.00	39.60	37.00	2.50 +0.15 -0.15	31.10	1010		
334	PPFM39	51.00	42.60	40.00		34.10	950		
335	PPFM42	54.00	45.60	43.00		36.50	890		
336	PPFM45	57.00	48.60	46.00		39.50	860		
337	PPFM48	60.00	51.60	49.00		41.90	790		

Note: There is a permitted moulding flashline on the inner diameter C in accordance with AGS 1186 All dimensions in mm

☑ NEW PM3000 LOCKSEALS RANGE MECHANICAL BOND, CHEMICAL BOND OR BOTH

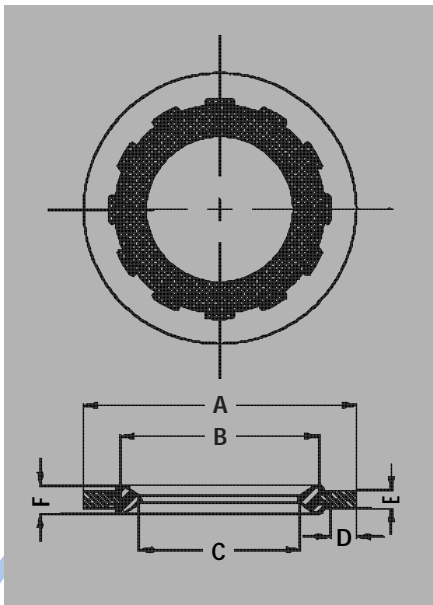

ASHTON REFERENCE	SIZE	A +0.13 -0.13	B +0.13 -0.13	C +0.13 -0.13	D REF.	E +0.05 -0.05	F +0.10 -0.10
3270	3/8"	16.00	10.80	8.13	1.78	1.27	2.03
3249	1/2"	19.10	13.79	11.18	1.78	1.27	2.03
3217	5/8"	28.00	20.70	15.37	1.90	1.27	1.93
3250	3/4"	25.27	20.71	17.16	1.78	1.27	2.13

Note: There is a permitted moulding flashline on the inner diameter C in accordance with AGS 1186 All dimensions in mm